



CAVIBLASTER[™]

CAVIDYNE[™], LLC

P.O. Box 358628
Gainesville, FL 32635

Phone: (352) 275-5319
Web Site: www.caviblast.com

OPERATION
&
MAINTENANCE
MANUAL

Model 2022-U



CAVIBLASTER™



CaviDyne,™ LLC is not responsible for damages or injuries resulting from a failure to comply with instructions in this manual. Please read entire manual carefully before use.



The CaviBlaster™ 2022 must only be operated and maintained by trained personnel.



This equipment generates high pressure water and is intended for underwater use only. **Serious personal injury or death may result from improper use.**



Commercial Diver's gear should be used to operate the CaviBlaster™ system.



CAVIBLASTER™

TABLE OF CONTENTS

1.0 UNIT SPECIFICATIONS	5
2.0 GENERAL DESCRIPTION	6
2.1 Using this Manual	8
2.2 Conventions.....	9
2.3 Scope	9
2.4 Terms and Abbreviations.....	9
3.0 SAFETY INFORMATION	10
3.1 Personal Safety	10
3.2 Personal Protective Equipment.....	11
3.3 Modification to the Equipment.....	12
4.0 INSTALLATION.....	13
4.1 Uncrating and Lifting.....	13
4.2 Installation Location	14
4.3 Initial Set-Up	15
4.3.1 Connecting the Battery Terminals	15
4.3.2 Connecting the Water Source	16
5.0 OPERATION	20
5.1 Preparing the CaviBlaster™ for Operation	20
5.2 Startup of the CaviBlaster™	21
5.3 Normal Operation	22
5.4. Adjusting the CaviBlaster™ for Maximum Performance.....	24
5.5. Recommendations for Effective Results	27
5.6. Shutting Down the CaviBlaster™	27
6.0 MAINTENANCE	30
6.1 Preventive Maintenance Recommendations	31
6.2 Diesel Engine Service.....	32
6.3 Pump Service	32
6.4 Inspection/Cleaning of Water Inlet Strainer	32
6.5 Inspection / Maintenance of the Belt Drive System.....	34
7.0 WINTERIZATION	37
8.0 TROUBLESHOOTING	37
9.0 REPLACEMENT PARTS.....	39
APPENDIX - COMPONENT LITERATURE.....	40

LIST OF FIGURES & TABLES

Figure 1.1 – CaviBlaster™ 2022-U Specifications 5

Figure 2.1 – CaviBlaster™ 2022 General Features 7

Figure 2.2 – CaviBlaster™ 2022 Control Panel 8

Figure 4.1 – Lifting Guidelines..... 13

Figure 4.2 – Installation Guidelines 14

Figure 4.3 – Reconnecting the Battery Terminals 16

Figure 4.4 – Gravity Feeding Source..... 17

Figure 5.1 – Engine Emergency Shut-Down and Throttle Control..... 23

Figure 5.2 – Lance Pressure Calibration 23

Figure 5.3 – Lance Position for Best Results 23

Figure 6.1 – Inspection / Cleaning Water Filter 33

Figure 6.2 – Inspection / Belt tension 35

This space intentionally left blank

1.0 UNIT SPECIFICATIONS

The CaviBlaster™ 2022-U power unit consists of a 34HP Kohler KDW 1404 diesel power-pack and a UDOR NX 75/150 positive displacement pump. Detailed performance and specifications are listed below:

CaviBlaster™ 2022-U Specifications	
Nominal Pump Flow	20 GPM (75.6 LPM)
Operating Pressure	2200-PSI (152 BAR)
Engine	34 HP, Diesel Powered (Kohler KDW 1404)
Installation Environment	Outdoor enclosed or exposed <i>See Section 4 for installation requirements</i>
Fuel Requirements	Diesel fuel (ASTM Grade No. 1-D or 2-D)
Fuel Tank Capacity	6.5 Gallons (24.5 Liters)
Water Inlet Pressure Limits	0-PSI (Atmospheric Pressure) to 50-PSI Maximum (0 BAR to 3.5 BAR) <i>See Section 4 for further requirements</i>
Overall Unit Dimensions (L x W x H)	42" x 38" x 37" (107 cm x 97 cm x 94 cm)
Maximum Pressure Hose Length	600 LF (200 meters) of 3/4" diameter thermoplastic
Power Unit Weight (Dry)	770 LBS (350 KG)
Zero-Thrust Lance Weight	13 LBS (5.9 KG)

Figure 1.1 – CaviBlaster™ 2022-U Specifications

This space intentionally left blank

(EOS)

2.0 GENERAL DESCRIPTION

The CaviBlaster™ 2022 high-pressure water power unit allows the operator to use the water flow and pressure to generate cavitation at the end of the proprietary nozzle.

The CaviBlaster™ cleans the surface of any underwater structure using the energy released by the implosion of the bubbles during the cavitation process. When directed at the surface being cleaned, the energy released by the collapsing bubbles causes marine growth to be removed from the surface.

The system consists of a portable, zero-thrust lance, connecting high-pressure hose and a diesel-powered, high-pressure pumping unit. The zero-thrust lance uses a trigger-operated valve to control the water stream off and on. If the valve is closed, the power unit goes into bypass mode unloading the engine and the pump.

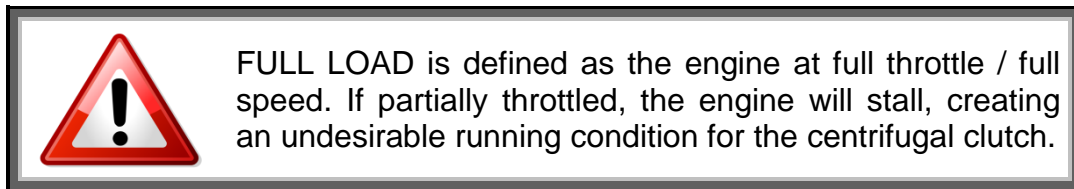

The CaviBlaster™ 2022 power unit is a complete “plug and play” system built into a self-supporting frame that allows quick deployment and/or installation of the unit. Water can be supplied from either a pressurized source, directly from the natural source via an electric booster pump supplied with the power unit, or from a gravity storage feed tank.

The unit is equipped with many features to maintain operator safety while operating at pressures of 2,200-psi (152 bar).



CAVIBLASTER™

*For more information on the CaviBlaster™ system please visit us at:
www.caviblast.com*

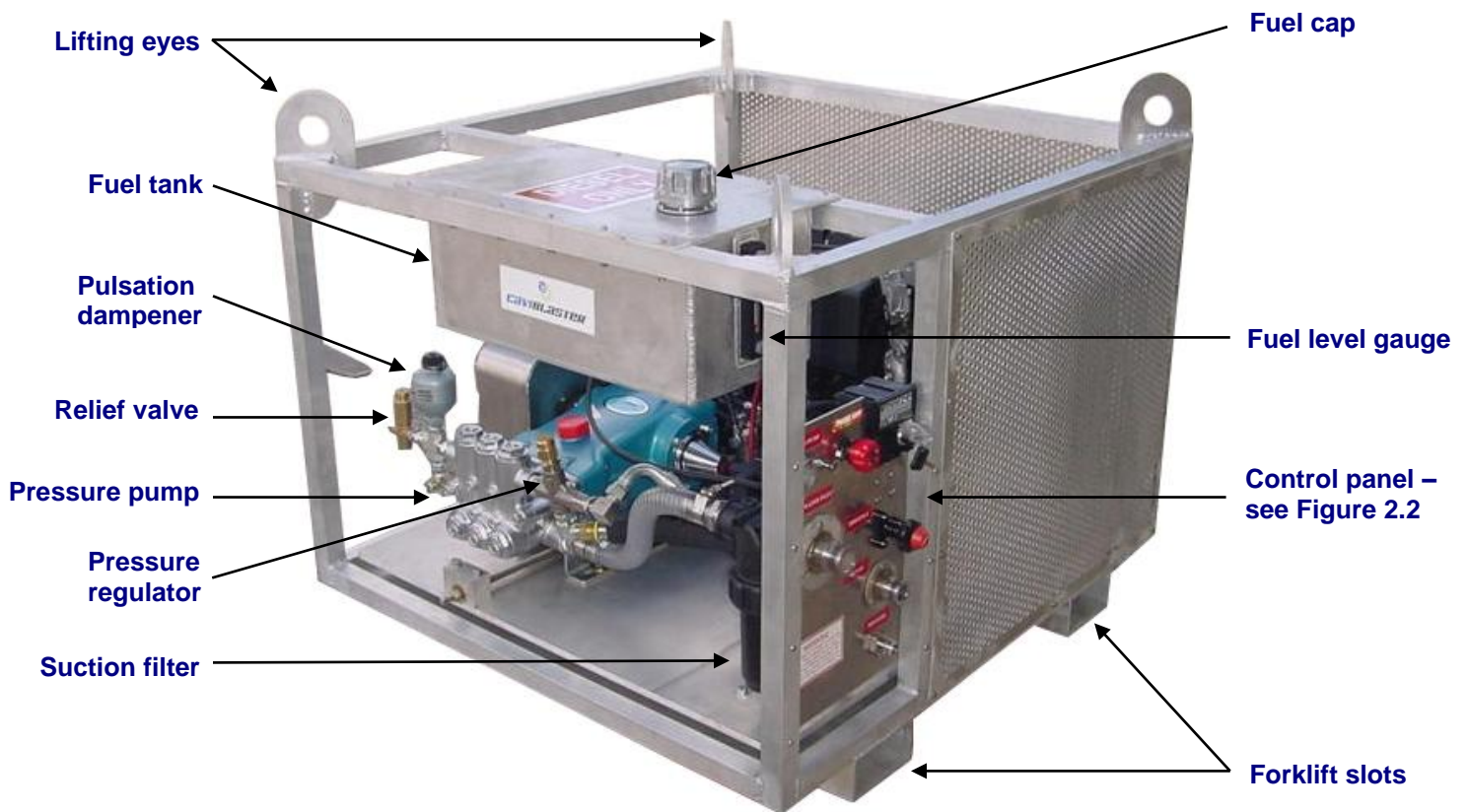

Figure 2.1 – CaviBlaster™ 2022 General Features



CAVIBLASTER™



Figure 2.2 – CaviBlaster™ 2022 Control Panel

2.1 Using this Manual (Version 1.2)

Every attempt has been made to ensure that this documentation is complete and accurate at the time of publication. It is imperative; however, that anyone attempting to use this manual must have good comprehension of how this equipment operates. Further, this manual can in no way replace the common sense of an individual. If at any time this manual seems to contradict itself, or common sense, discontinue the procedure, re-read the section, and seek assistance from CaviDyne™ or other personnel familiar with the operation of this equipment.

NOTE FOR ELECTRONIC COPY OF THIS MANUAL

The electronic version of this manual contains many additional resources such as component data sheets and service manuals. To best utilize these resources, it is recommended to view with [Adobe Reader](https://www.adobe.com) version 7.0 or higher. Go to www.adobe.com for this free software download.

2.2 Conventions

The first time a component is mentioned, it is typically followed by a figure reference; e.g., Emergency Stop button (See Figure 2.1). Figure numbers and section numbers are always coincident.

When other sections are referenced the *SECTION NAME* will appear in italic caps. The electronic version allows users to click on the section name or figure reference to jump to that section. The words “**This space intentionally left blank**” will appear where there is more than 3 inches of white space.

(EOS) will appear above the page number on the last page of each section.

2.3 Scope

This manual covers installation, operation, and maintenance of the CaviBlaster™ 2022. It is essential that personnel who will operate and/or service this equipment familiarize themselves with this manual. Standard components, such as the unit engine and pump, are covered by the manufacturer’s literature found in the Appendix.

2.4 Terms and Abbreviations

CCW	Counterclockwise
CW	Clockwise
EOS	End of Section
GPM	Gallons Per Minute
HP	Horsepower
LPM	Liters Per Minute
PPE	Personal Protective Equipment
PSI	Pounds Per Square Inch (without suffix, assumed to be gauge pressure).

(EOS)

3.0 SAFETY INFORMATION

The CaviBlaster™ 2022 power unit is an inherently powerful and potentially dangerous piece of equipment; however, with proper care and training it can be operated safely. The 2022 must only be operated by personnel that have read and understand this manual. It is intended to reinforce and review safety techniques to prevent personal injuries and property damage.

Users must comply with all local, state, and national laws concerning high-pressure water jetting equipment as well as all underwater work regulations.

It is strongly recommended that this entire manual be reviewed in-depth before operating or servicing this equipment. Service work should only be performed by individuals who are proficient in using this equipment. Refer to the applicable section in this manual for the correct procedures prior to any installation, setup, or maintenance work.

3.1 Personal Safety

Operation of the CaviBlaster™ 2022 underwater cleaning system must only be attempted by commercial divers or other personnel who have been trained in its use. Appropriate protective equipment should always be worn. Operation of the system without the proper equipment and training can result in personal injury.



CaviDyne™, LLC is not responsible for damages resulting from a failure to comply with instructions in this manual. Please read carefully before use.



If maintenance or repair of the CaviBlaster™ lance is being conducted out of the water, remember that the zero-thrust lance has front and rear jets. Never direct the jet streams at a person or animal. Never direct the jet streams toward power lines or other high voltage equipment.



Ensure that there is a safe area to work while operating the CaviBlaster™ 2022.



Seek immediate medical attention if the operator suffers an injury as the result of contact with the high-pressure water stream. **Serious personal injury can result from an untreated water injection wound.**

3.2 Personal Protective Equipment

Always wear appropriate Personal Protective Equipment (PPE) when operating this equipment.

Personnel operating or working in the vicinity of the power unit should wear appropriate hearing protection when the CaviBlaster™ system is in use. If the diver is not wearing a diving helmet, hearing protection is recommended. CaviDyne™ suggest wearing vented earplugs, such as “Doc’s Proplugs”, for diver hearing protection.

The operators of the CaviBlaster™ system should always wear neoprene or heavy rubber gloves to provide protection to the hands and, in particular, to the nails. The gloves will absorb most of the energy produced by bursting cavitation bubbles and prevent the cavitation bubbles from contacting the operators’ hands. The gloves will also protect operators’ hands from the initial shockwave when the lance is activated.



Failure to wear appropriate PPE may result in personal injury.

3.3 Modification to the Equipment

Do not make any unauthorized modifications or repairs to this equipment. Components used throughout this assembly were specifically designed or selected to safely meet the unique high-pressure requirements. Only replace parts with those recommended by or supplied by CaviDyne™. Any unapproved modifications will void the equipment warranty. Unauthorized modification or part substitution can result in serious personal injury or property damage.



Unauthorized replacement of any part may lead to catastrophic equipment failure and serious personal injury.

This space intentionally left blank

(EOS)

4.0 INSTALLATION

The CaviBlaster™ 2022 must be installed in accordance with the requirements outlined below. The unit can be installed in a vehicle to allow for maximum mobility and flexibility.

4.1 Uncrating and Lifting

Unpack the equipment and inspect for damage. If damage is found, immediately contact CaviDyne™ and the shipping company. *If the unit will not be installed immediately, provide adequate indoor storage to protect against damage.*

The CaviBlaster™ power unit should be lifted from underneath the frame using the forklift channels or by using the lifting eyes provided on top of the frame. Verify that lifting equipment is rated for the weight listed in Section 1.0 *UNIT SPECIFICATIONS* and that the unit is stable before lifting.

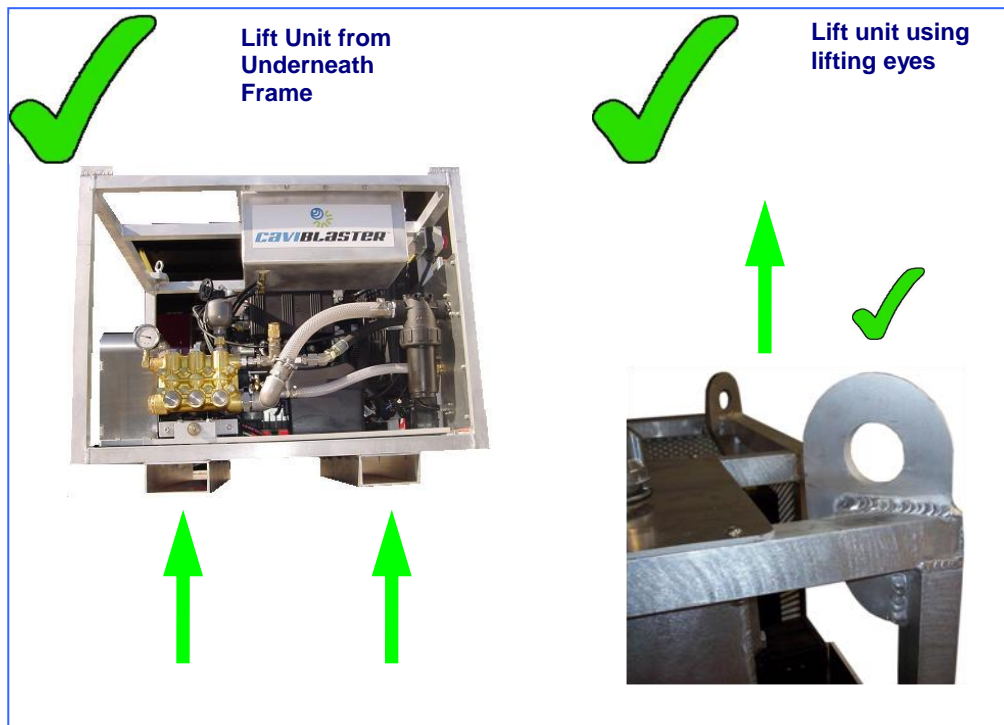

Figure 4.1 – Lifting Guidelines

4.2 Installation Location

For maximum flexibility the CaviBlaster™ power unit should be installed in an area where it is capable of reaching both its water source and anticipated cleaning targets within acceptable hose lengths. The CaviBlaster™ power unit can be installed in an enclosed* or open environment.

*** Enclosed installations will require provisions for adequate engine cooling air flow and for venting of engine exhaust. See Figure 4.2 below.**

Installation location must be a level surface able to safely support the unit weight listed in Section 1.0 *UNIT SPECIFICATIONS*. Orient unit to allow unrestricted access to the hose connection plate and control panel, located on the front of the unit. Allow a minimum of three feet behind the unit and access from above to conduct service and repair work. Take note of frequently serviced areas such as the engine and fuel tank.

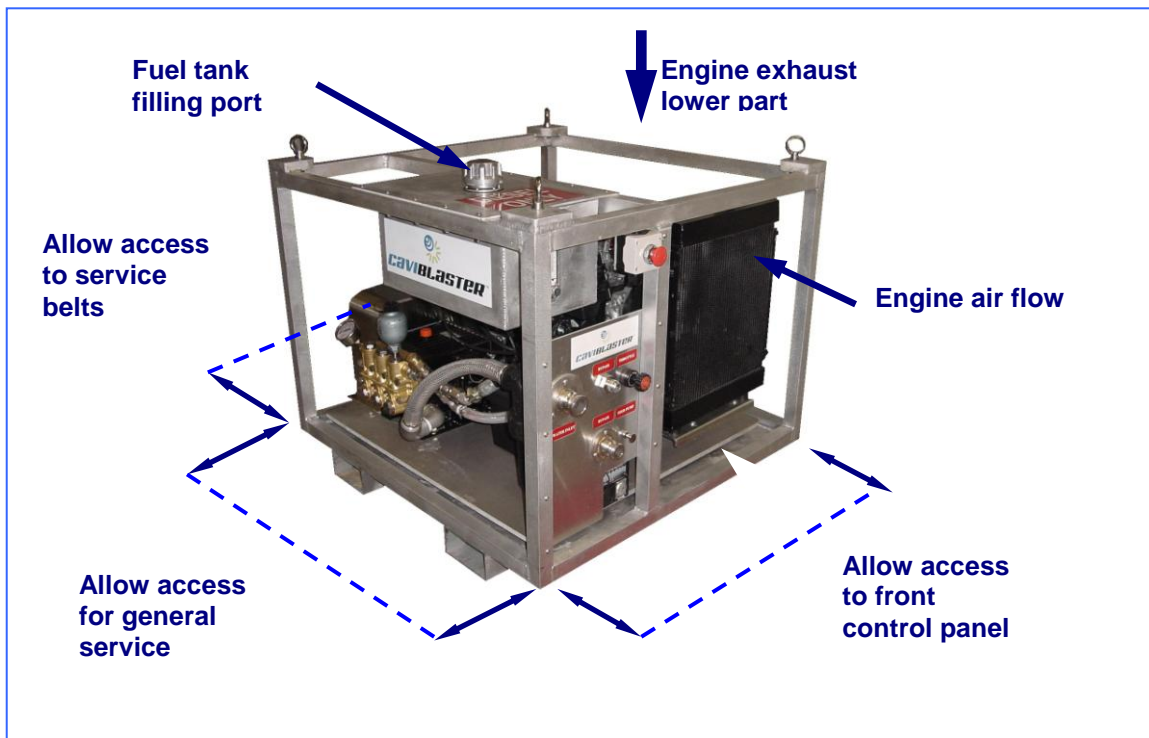

Figure 4.2 – Installation Guidelines

4.3 Initial Set Up

After first receiving the CaviBlaster™ power unit, the following must be checked and completed:

- 1) Connect the battery (See Section 4.3.1).
- 2) Add engine oil (See Engine Manual located in the *APPENDIX*).
- 3) Add engine coolant (See Engine Manual located in the *APPENDIX*).
- 4) Add pump oil (See Pump Manual located in the *APPENDIX*).
- 5) Connect the feed or suction hose (See Section 4.3.2).
- 6) Connect the bypass hose (See Figure 2.2).
- 7) Connect the pressure hose (See Figure 2.2).
- 8) Connect the electric feed pump (See Section 4.3.2).
- 9) Fill the fuel tank (See fuel requirements in Engine Manual located in the *APPENDIX*).



Engine and/or pump fluids may have been removed for shipment. Check fluid levels prior to starting.

4.3.1 Connecting the Battery Terminals

For shipping purposes, the battery terminals have been disconnected. To reconnect the battery, reference Figure 4.3 and the procedure below:

1. Push IN the Emergency Stop button located on the front control panel (See Figure 2.2).
2. Open the battery box by loosening the strap and removing the cover.
3. Connect the battery terminals as follows:
 - RED to positive terminal**
 - BLACK to negative terminal**
4. Tighten the terminal screws securely.
5. Replace the battery cover and secure with strap.



CAVIBLASTER™

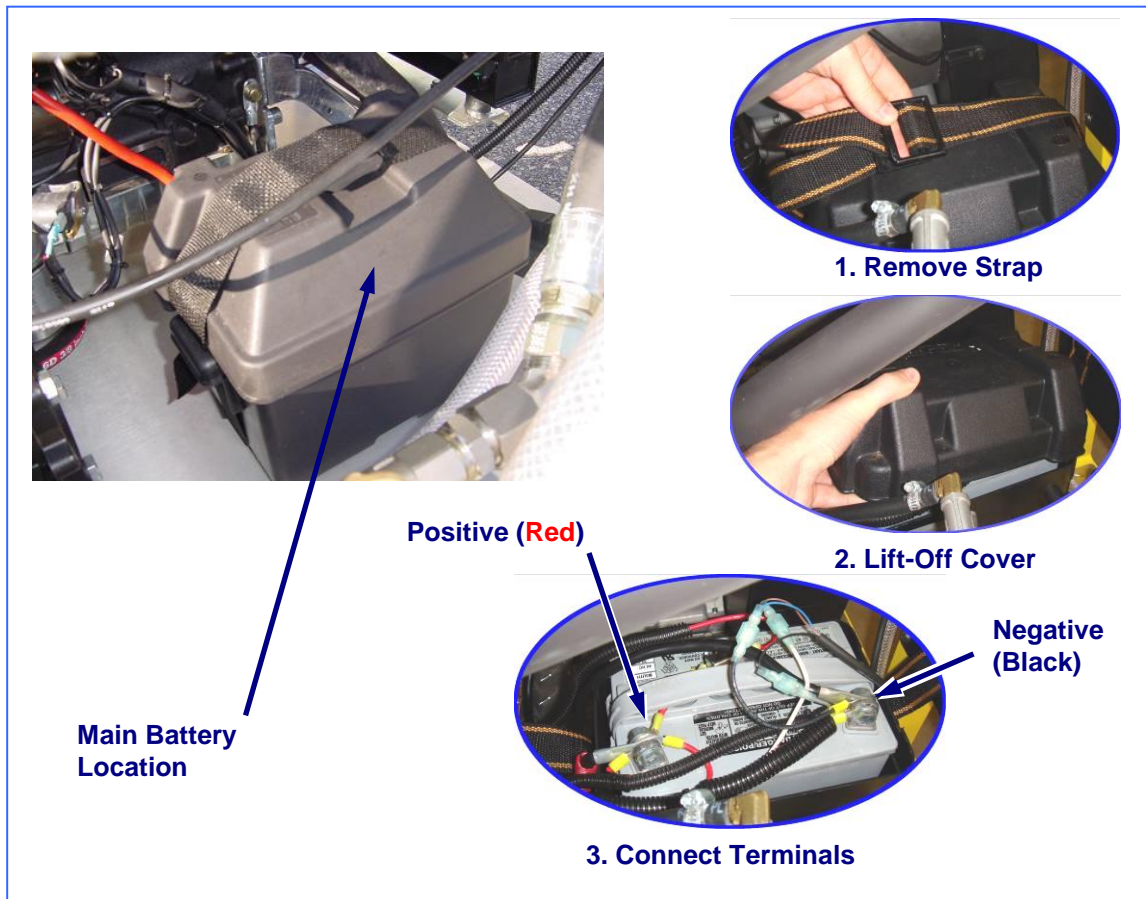

Figure 4.3 – Reconnecting the Battery Terminals

4.3.2 Connecting the Water Source

The CaviBlaster™ power unit can be used with seawater or fresh water. It must be flushed with fresh water for 1-2 minutes after each use in seawater to ensure long service life.



The CaviBlaster™ 2022 must be flushed and rinsed with fresh water after every use in seawater.

**CAVIBLASTER™**

Failure to flush and rinse the power unit after use in seawater will result in increased wear and tear on components and in decreased service life.



Failure to flush and rinse the unit can cause the pump valve(s) to stick in the open position. This will prevent the system from producing the correct operating pressure.

The feed water inlet connection is located on the control panel (See Figure 2.2). An electric submersible water pump is supplied to provide positive inlet water pressure to the main pressure pump. Two water supply conditions are acceptable for the CaviBlaster™ power unit.

- Forced inlet water condition using the supplied electric water pump or an outside water source capable of supplying at least 25 GPM (95 LPM) at a **maximum pressure of 50-PSI (3.5 BAR)**.
- Gravity feeding water source (See Figure 4.4). In this case the electric pump is not required. Use a hose with a diameter of at least 1-1/4" to connect the water tank to the power unit

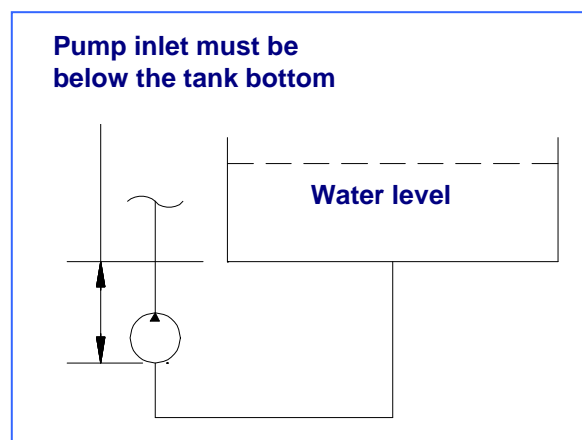

Figure 4.4 – Gravity Feeding Source



CAVIBLASTER™

To use the feed pump supplied with the system:

- Turn the engine ignition key to OFF (See Figure 2.2).
- Push IN the Emergency Engine Shut-Down button to ensure that power to the engine has been disconnected. (See Figure 2.2).
- Connect the cam-lock socket on the 1-1/4" clear PVC feed hose to the water inlet connection on the control panel (See Figure 2.2).
- Connect the electrical plug on the feed pump power cable to the matching receptacle on the control panel (See Figure 2.2).
- Submerge the feed pump into the water source.
- Release the Emergency Engine Shut-Down button.
- Pull the feed pump ON/OFF switch out to activate the feed pump (See Figure 2.2).
- It is important not to operate the feed pump for long periods of time without the engine operating as this will discharge the battery.

To use force feed from an alternate source:

- Turn the engine ignition key to OFF (See Figure 2.2).
- Push IN the Emergency Engine Shut-Down button to ensure that power to the engine has been disconnected. (See Figure 2.2).
- When feeding the CaviBlaster™ with an alternate water source, **the source must supply water at a volume of greater than 20 gallons per minute at a maximum of 50-psi (3.5 bar).**
- Connect a 1-1/4" cam-lock socket on the water supply hose to the water inlet connection on the control panel (See Figure 2.2).
- Turn on the alternate water source.
- Release the Emergency Engine Shut-Down button.



Ensure that the feed hose is connected to the inlet connection and the water supply is on prior to starting the pressure pump. Failure to supply to the pressure pump will cause damage to the pump.

**CAVIBLASTER™**

To use gravity feed:

- Locate the water supply tank so that the bottom of the tank is higher than the water inlet on the control panel (See Figures 2.2 and 4.4).
- Turn the engine ignition key to OFF (See Figure 2.2).
- Push IN the Emergency Engine Shut-Down button to ensure power has been disconnected. (See Figure 2.2).
- Connect a minimum 1-1/4" hose to the water inlet 1-1/4" cam-lock plug.
- Connect the other end of the hose to the water supply tank.
- Make sure the lowest point in the hose line is the connection with the power unit.
- Release the Emergency Engine Shut-Down button.
- It is essential that adequate water is supplied to the water supply tank to maintain the water level several inches above the bottom of the tank. Failure to maintain an adequate water level in the supply tank could starve the pressure pump of water causing damage to the seals or other components of the pressure pump.

Ensure that the water source can reliably deliver the maximum pump flow of 20 GPM (76 LPM). A minimum flow of 25 GPM (95 LPM) is recommended to ensure that the pump is not starved of water. If connecting to a tank, locate the bottom of the tank above the water inlet connection on the power unit to ensure a flooded suction line (See Figure 4.4).

This space intentionally left blank

(EOS)

5.0 OPERATION

The CaviBlaster™ 2022 should be operated by two (2) properly trained individuals. One, the diver, operates the zero-thrust lance, while the other operates the power unit. Both operators should be in audio or visual communication with each other.



The CaviBlaster™ 2022 should only be operated by properly trained personnel who are familiar with the contents of the manual. Review the safety requirements found in Section 3 before operating.

5.1 Preparing the CaviBlaster™ for Operation

The following checklist should be completed in advance, so that the unit is always ready for immediate use. This should be completed after each use.

- 1) Inspect the CaviBlaster™ power unit, hoses, JIC fittings and lance for any signs of damage
- 2) Inspect the inline strainer to ensure that it is not clogged (See Figure 6.1).
- 3) Check for proper engine oil level (See engine Owner's Manual found in the *Appendix*). Add lubricating oil (SAE 10W40) if necessary.
- 4) Check for proper pressure pump oil level (See pump Owner's Manual found in the *Appendix*). Add hydraulic oil (SAE 30 non-detergent) if necessary.
- 5) Check fuel tank (See Figure 2.1) for proper diesel fuel level. Add diesel fuel (ASTM Grade No. 1-D or 2-D, or EN 590) if necessary.



Incorrect fuels should not be used as they may prove hazardous.



CAVIBLASTER™

5.2 Startup of the CaviBlaster™

Before starting the CaviBlaster™ 2022 power unit, review all safety requirements found in Section 3.0 *SAFETY INFORMATION*. This equipment should only be operated by individuals who have read and understand the CaviBlaster™ Operation and Maintenance Manual.

- 1) Verify that the unit has been properly prepared for operation as described in Section 4.
- 2) Verify that the lance is properly connected and the mechanical trigger is released.
- 3) Verify that the Emergency Engine Shut-Down knob (See Figure 2.2) is released by twisting and pulling it out.
- 4) Verify that the throttle cable is fully depressed (See Figure 5.1).
- 5) **Apply appropriate hearing protection prior to starting engine.**
- 6) Insert the key into the ignition switch on the ignition panel (See Figure 2.2). Turn the key clockwise one position to heat the glow plugs. Once the plug preheat light (the top right light on the panel) turns off, turn the key farther clockwise to start the engine. If the engine does not start within 10 seconds, return the key to the "OFF" position and wait at least 30 seconds before operating the starter again. Once the engine starts, release the key, allowing it to return to the "ON" or running position.
- 7) Run the engine at idle speed for a minimum of 20 seconds (20") at operating temperatures above 41°F (5°C). For lower operating temperatures, run engine at idle speed for a minimum of one minute (1').



DO NOT THROTTLE UP THE ENGINE UNTIL THE DIVER IS READY FOR UNDERWATER OPERATION.



The engine must be run at full throttle / full speed. If partially throttled, the engine will stall, creating an undesirable running condition for the centrifugal clutch.



CAVIBLASTER™

5.3 Normal Operation

Normal operation of the CaviBlaster™ system is defined as user control of water flow via the lance trigger. Control of the power unit from the lance trigger is accomplished by a mechanical shut-off valve in the lance. Should a problem develop with the control valve, discontinue using the CaviBlaster™ until fixed.

The CaviBlaster™ 2022 power unit is designed to operate in two modes: idle and full throttle. Less than full throttle will result in malfunction of the belt drive system and the performance of the centrifugal clutch.



Review the safety requirements for PPE and safe operation before proceeding.

- 1) Startup the power unit as described in Section 5.2.
- 2) Connect the lance to the high-pressure hose and unroll sufficient length of hose to reach the operating location.
- 3) When the diver is ready to commence cleaning operations, ensure that the lance is submerged in water. **Ensure that the power unit operator and other persons working in the vicinity of the power unit wear appropriate hearing protection when the engine is running.** If the diver is not wearing a helmet, hearing protection is recommended. CaviDyne suggests vented earplugs such as “Doc’s Proplugs” for diver hearing protection.
- 4) **Wear neoprene or rubber gloves to protect the hands and follow all safety regulations that may be applicable to the work being performed.**
- 5) The lance trigger should be in open or “ON” position (See Figure 5.3) when throttling up the engine to engage the pressure pump. This will prevent the pressure pump from being in a loaded condition which will cause the clutch and belt to slip while they are engaging the pressure pump.
- 6) Throttle the engine up by completely pulling the black throttle cable knob all the way out and twisting the knob to lock it (See Figure 5.1).
- 7) Activate the cleaning cavitation stream by squeezing the trigger to the open or “ON” position (See Figure 5.3). Release trigger to stop the water flow and direct to bypass.



- 8) If the diver operating the unit must be replaced or the cleaning operation must be interrupted or terminated, disengage the pressure pump by pushing the throttle lever in to the idle position (See Figure 5.1) **and then release the water pressure in the hose(s) by squeezing the lance trigger to the open or “ON” position (See Figure 5.3) while under water.** Revert back to step 3 of the operating instructions when the diver or replacement is ready to continue cleaning.

 **Although the CaviBlaster™ system is safe to use when submerged in water, the system generates a high-pressure (up to 2,200-psi [152 bar]) water stream, which can cause injury when the lance is out of the water. ALWAYS keep the lance submerged when the pressure pump is engaged.**

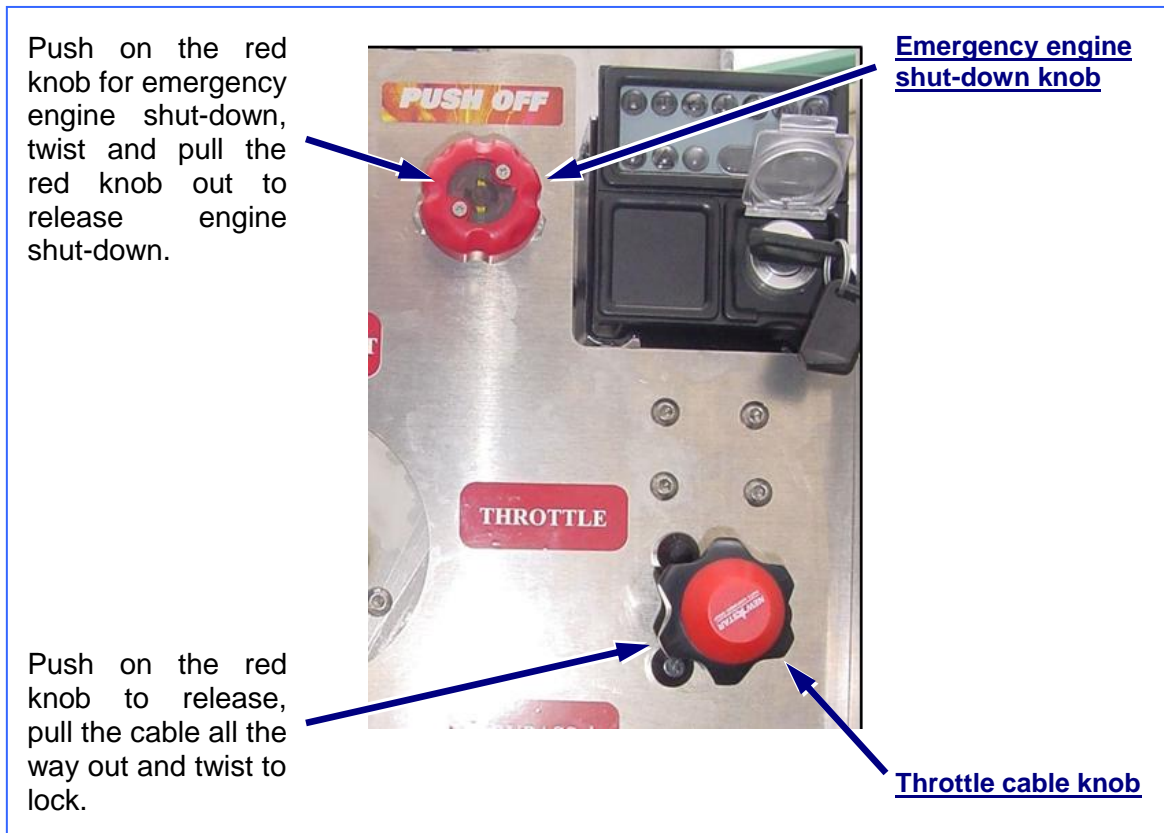

Figure 5.1 – Engine Emergency Shut-Down and Throttle Control



CAVIBLASTER™

5.4. Adjusting the CaviBlaster™ for maximum performance

The pressure at the nozzle of the zero-thrust lance has to be maintained within certain limits to achieve cavitation and for best performance results. If using a calibration pressure gauge situated between the pressure hose and the CaviBlaster™ lance, the water pressure should be 2,200-psi (152 bar) with the lance submerged and the lance trigger in the open or “ON” position. For best results, repeat this calibration procedure if cleaning performance degrades, or every 3 months at a maximum.



A CALIBRATION TEST GAUGE IS RECOMMENDED WITH EVERY UNIT. CONNECT BETWEEN THE END OF THE THERMOPLASTIC HOSE AND THE LANCE.

To calibrate the pressure at the zero-thrust lance, follow the procedure below:

- Stop the power unit and pull the lance trigger to discharge any residual pressure in the hose lines.
- Disconnect the lance with its whip hose from the main hose line.
- Attach the calibration gauge and tighten the JIC connections.
- Submerge the lance. Because of the danger of the operator coming in contact with either of the water streams from the cavitating or zero-thrust nozzles, **Cavidyne does NOT recommend calibrating the lance out of the water. Use extra care to avoid both water streams if doing so.**
- Ensure that both the cavitation and zero-thrust nozzles are pointed away from the diver's or operator's hands, arms and body.
- Start the power unit (See Section 5.2).
- Pull the lance trigger to the open or “ON” position (See Figure 5.3).
- Throttle the engine to full speed (See Section 5.3).
- Hold the lance tight and observe the calibration gauge (See Figure 5.2).
- The power unit operator should turn the knob on top of the pressure regulating valve until pressure reads 2,200-psi (152 bar) on the calibration gauge. Turning the knob clockwise will increase the pressure and turning it counter clockwise will decrease the pressure.



CAVIBLASTER™

To calibrate the pressure at the CaviBlaster™ power unit, the water pressure at the power unit will need to be higher to account for sidewall friction loss in the pressure hose. The pressure at the pump should be 2,200-psi (152 bar) plus 0.5-psi per foot (0.11 bar per meter) of thermoplastic pressure hose. For example, if using the CaviBlaster™ with 100 feet (30 meters) of pressure hose, the pressure gauge located next to the pump should indicate 2,250-psi (155 bar). Pressure adjustments are made by turning the knob on top of the pressure regulating valve in the same manner as described above.



DO NOT ADJUST THE PRESSURE AT THE LANCE TO MORE THAN 2,200-PSI. HIGHER PRESSURE WILL NOT IMPROVE PERFORMANCE.



PUMP AND HOSES ARE RATED FOR 2,500-PSI. PRESSURES ABOVE 2,500-PSI COULD RESULT IN PUMP AND/OR HOSE FAILURE.

This space intentionally left blank

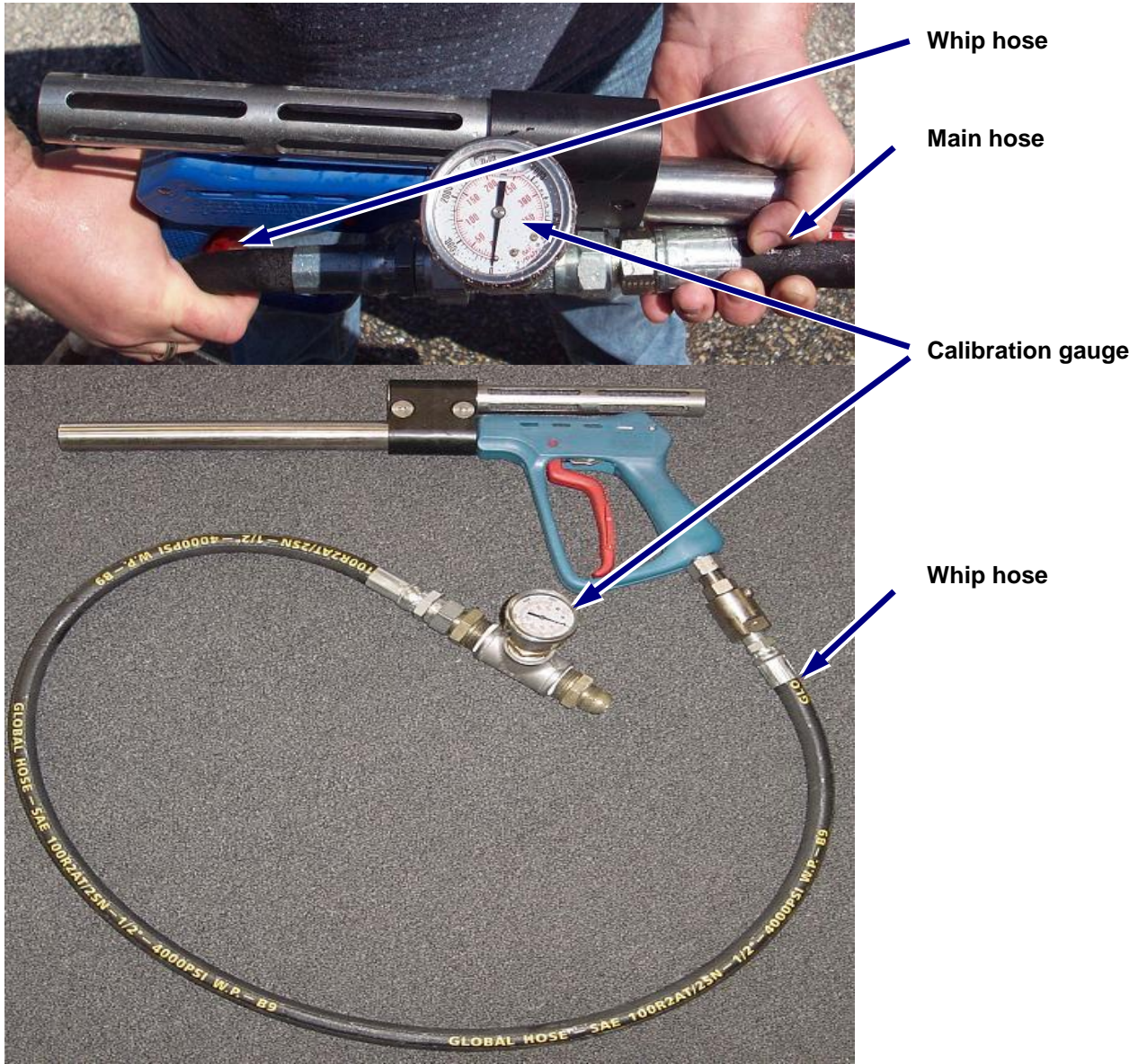

Figure 5.2 – Lance Pressure Calibration



CAVIBLASTER™

5.5. Recommendations for Effective Results

Once the engine is throttled up to operating speed and the water trigger is pulled, the diver has to find the most effective distance between the lance nozzle and the surface being cleaned.

When the diver is ready to commence cleaning operations, ensure that the lance trigger is in the open or “ON” position (See Figure 5.3), the lance is submerged in the water and the feed pump is operating prior to throttling up the engine. Ensure that the power unit operator and other people working in the vicinity of the power unit wear appropriate hearing protection when the engine is running.

1. Engage the pressure pump by pulling the engine throttle lever (See Figure 5.1) to the operating speed position (fully extended) to engage the centrifugal clutch. Tighten the thumb screw to hold throttle in operating speed position.
2. **The most efficient operating technique is to hold the nozzle 2-5 inches (5-12 cm) away from the surface to be cleaned and at a 25 to 45 degree angle to the surface being cleaned (See Figure 5.3).** The diver needs to observe the shape of the cavitating jet cone. At greater depths, the higher ambient pressure will cause the jet cone to be shorter. The widest zone of the cone is the most efficient part of the cavitating jet. Placing the nozzle closer than 2 inches (5 cm) from the surface being cleaned will not allow for efficient cavitation performance and will degrade the cleaning capability of the CaviBlaster™ system.
3. Follow all safety regulations that may be applicable to the work being performed.
4. If the diver operating the CaviBlaster™ unit must be replaced or the cleaning operation must be terminated, disengage the pressure pump by pushing the throttle lever in to the idle position (See Figure 5.1) and release the water pressure remaining in the hose(s) by moving the lance trigger to the open or “ON” position while under water. Revert to step 1 of the operating instructions when the diver or replacement is ready to continue cleaning.

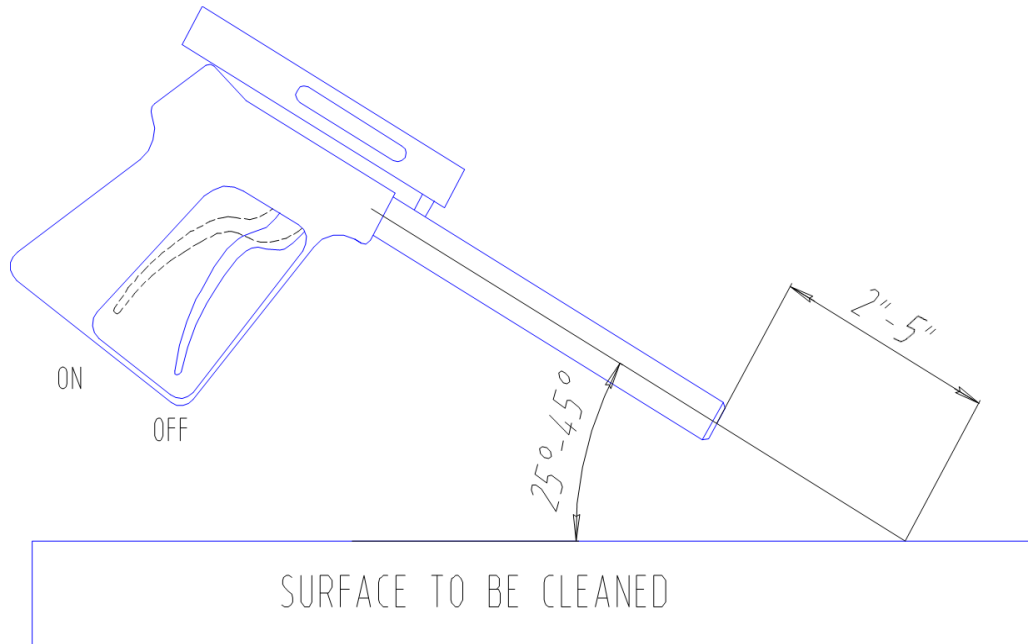

Figure 5.3 – Lance Position for Best Results

This space intentionally left blank



CAVIBLASTER™

5.6 Shutting Down the CaviBlaster™

1. Adjust the engine speed to idle by pushing on the red throttle cable knob (See Figure 5.1). This will disengage the clutch and pressure pump.
2. Run the engine at idle speed for a few minutes.
3. Push the feed pump ON/OFF switch in to stop the pump (See Figure 2.2). If using force feed from an alternate source or if using gravity feed, shut off the supply of water to the pressure pump.
4. Shut off the engine by turning the key counter- or anti-clockwise or to the "OFF" position (See Figure 2.1).
5. **Squeeze the lance trigger to the open or "ON" position (See Figure 5.3) to release the water pressure remaining in the hose(s) while the lance is submerged.**
6. It is now safe to remove the lance from the water.
7. Flush the system and rinse the power unit with fresh water at the end of the day.

This space intentionally left blank

EOS

6.0 MAINTENANCE

Maintenance on this unit should be restricted to authorized personal that have been properly trained. Review this manual, especially Section 3.0 *SAFETY INFORMATION*, prior to performing any service on this equipment.



Equipment must be OFF prior to performing any service work.



Only replace parts with those supplied or approved by CaviDyne™. Use of any other parts may lead to equipment failure and severe personal injury.



CAVIBLASTER™ MUST BE FLUSHED AND RINSED WITH FRESH WATER AFTER EACH USE IN SEA WATER.



FAILURE TO FLUSH AND RINSE THE UNIT WILL RESULT IN PREMATURE WEAR AND TEAR ON THE COMPONENTS AND DECREASED SERVICE LIFE.



Failure to flush and rinse the unit can cause the pump valve(s) to stick in the open position. This will prevent the system from producing the correct operating pressure.



CAVIBLASTER™

6.1 Basic Preventive Maintenance Recommendations

	After Every Use	Every 6 Months or 125 Hours*	Every 12 Months or 250 Hours*	Every 12 Months or 500 Hours*	Every 1,000 Hours
Check engine oil level and add if low	X				
Check pump oil level and add if low	X				
Check coolant level and add if low	X				
Check drive belt for wear and replace if worn	X				
Check feed pump base plate strainer and clean if necessary	X				
Check in-line strainer cartridge and clean if necessary	X				
Inspect hoses for wear or damage ¹	X				
Check lance trigger for leakage and repair if necessary ²		X			
Replace engine oil and oil filter ³			X		
Replace engine fuel filter			X		
Replace engine air filter			X		
Check rocker arm valve clearance				X	
Clean and set injectors				X	
Replace pump oil ⁴				X	
Check pump valves and seals for wear & change if necessary					X

* Whichever occurs first.

- 1) If any hose damage is found, replace hose immediately.
- 2) Remove lance from water with system at operating pressure and trigger in the closed or "OFF" position. If water is leaking out of barrel or handle, the valve is worn and should be replaced.
- 3) The initial oil change is after 50 hours of operation. The oil change interval is every 125 hours if oil of a quality lower than prescribed by the manufacturer is used. See engine manufacturer's literature in the Appendix for additional recommendations.
- 4) The initial oil change is after 50 hours of operation. See pump manufacturer's literature in the Appendix for additional recommendations.

6.2 Diesel Engine Service

The diesel engine requires routine maintenance. Oil must be checked and changed regularly. Oil, air and fuel filters must be checked and changed regularly. The engine crankcase holds 3.2 qts. (3.0 L) and the oil filter an additional 0.2 qts. (0.2 L) of SAE 10W40 viscosity lubricating oil. For detailed information on these routine maintenance requirements as well as other service recommendations, please see the engine manufacturer's literature found in the *APPENDIX*.

6.3 Pump Service

The high pressure water pump requires minimal maintenance. The pump oil should be checked on a regular basis. The pump crankcase holds 44 oz. (1.3 L) of SAE 30 viscosity non-detergent hydraulic oil. See pump manufacturer's literature found in the *APPENDIX* for further information.

6.4 Inspection/Cleaning of Water Inlet Strainer

The water inlet strainer should be inspected after each use of the CaviBlaster™ 2022. To inspect and clean this strainer, follow the procedure below:

- 1) Isolate or disconnect the water source from the inlet connection to the power unit.
- 2) Unscrew the filter housing (turn CCW) (See Figure 6.1).
- 3) Pull filter bowl DOWN.
- 4) Remove the strainer.
- 5) Inspect the strainer and flush any debris clean with clean water.
- 6) Push strainer back into housing.
- 7) Push the bowl back onto filter housing.
- 8) Thread the housing nut CW by hand to tighten.

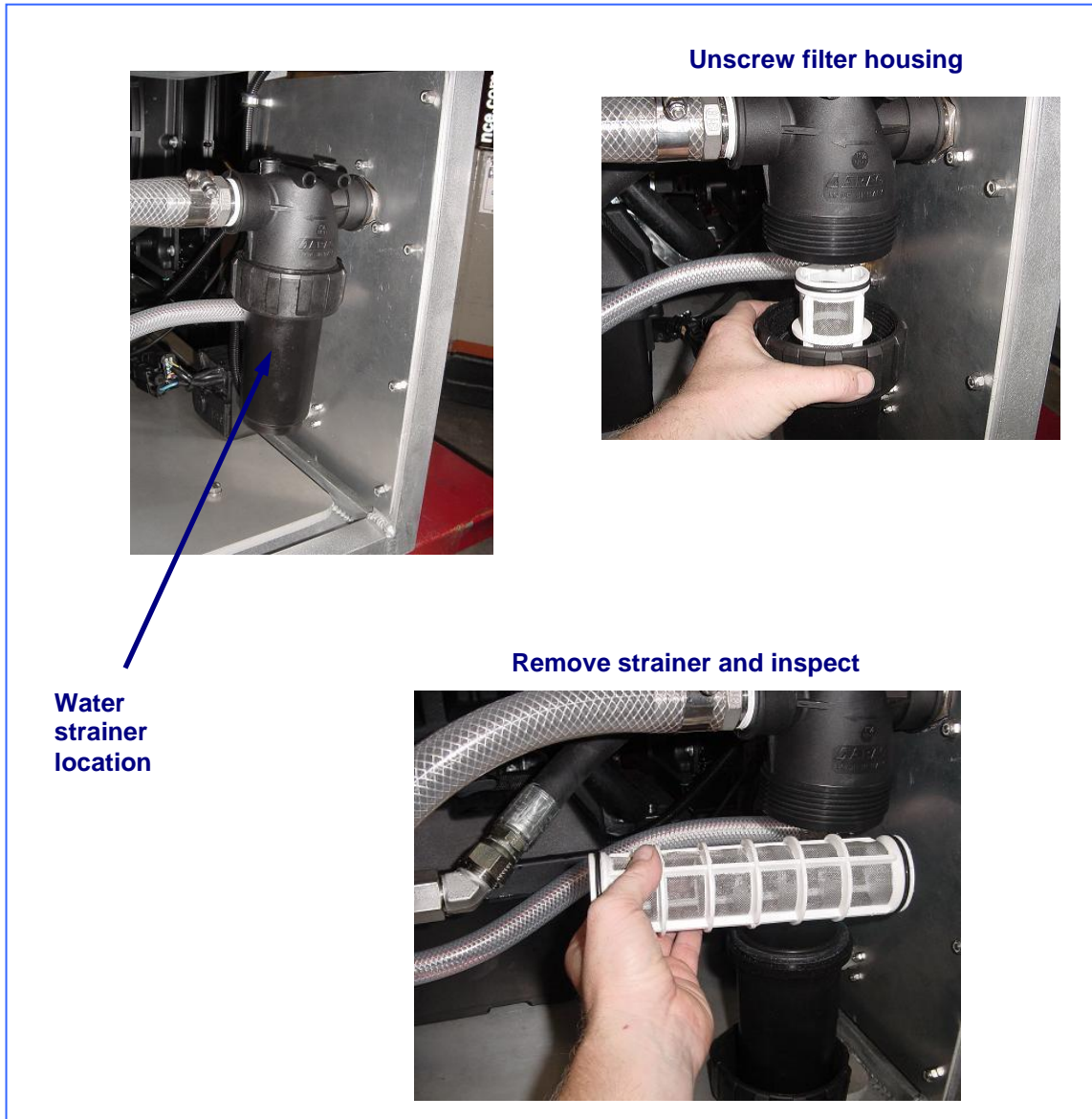
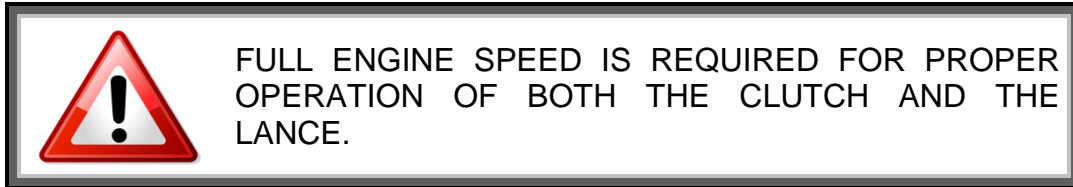

Figure 6.1 – Inspection / Cleaning Water Filter

6.5 Inspection / Maintenance of the belt drive system

The CaviBlaster™ 2022 is equipped with belt power transmission. The driver shaft has a centrifugal clutch with 1,400 RPM engagement speed.



To inspect the belts:

1. Remove the belt cover supported by 7 bolts (See Figure 6.2).
2. If belts need tightening, use the tightening nut to adjust (See Figure 6.2).
3. Release the bolts holding the pump rails.
4. Adjust Belt tension.
5. Tighten pump rails bolts.
6. Close belt guard.

This space intentionally left blank



CAVIBLASTER™

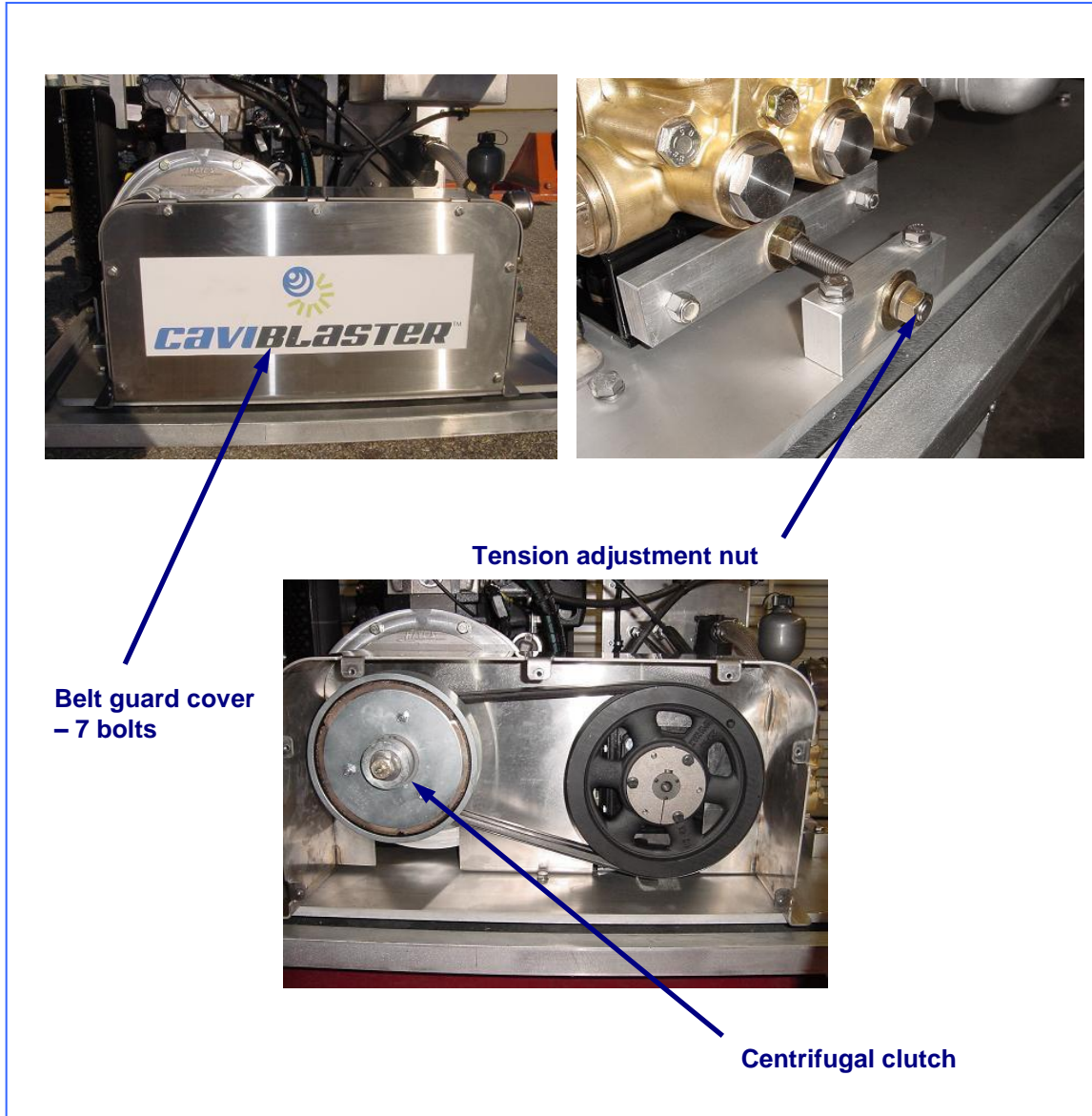

Figure 6.2 – Inspection / Belt tension.

(EOS)



CAVIBLASTER™

7.0 WINTERIZATION

The power unit should be winterized only if temperatures drop below 32 degrees Fahrenheit (0 degrees Celsius).

Total system displacement with 100 ft of hose (optional): 4.3 gallons.
Total system displacement without hose: 2.0 gallons.

To winterize the CaviBlaster™ 2022 power unit:

1. Fill a 5 gallon or larger tank with appropriate antifreeze solution.
2. Connect the suction of the unit to the antifreeze tank.
3. Start the unit and make sure the pump is primed.
4. Attach a minimal amount of pressure hose and direct the outlet of the hose into the antifreeze tank.
5. Run the unit without lance attached until antifreeze comes out of the end of the hose for 10 seconds.
6. Stop the unit.

Following this procedure will ensure that all the critical system components exposed to water have been flushed with antifreeze.

This space intentionally left blank

(EOS)



CAVIBLASTER™

8.0 TROUBLESHOOTING

1. ENGINE DOES NOT TURN OVER

- Verify that the Emergency Stop button is released
- Verify that the battery terminals are clean and tight
- Verify battery charge
- Check the alternator belt tension

2. ENGINE TURNS OVER BUT DOES NOT START

- Check fuel level
- Check fuel filter
- Check fuel line for air lock
- Verify that fuel pump solenoid is not stuck

3. ENGINE THROTTLES UP, BUT STALLS AFTER FEW SECONDS

- Verify that drive belts are tensioned (follow procedures in Section 6.5)
- Check that pressure regulator / unloader switches to by-pass mode
- Check mechanical stop on the throttle cable if at end position

4. ENGINE SPEEDS UP, BUT WATER DOES NOT GO OUT THE LANCE

- Verify inlet water supply
- Ensure that the power unit is not located too far above the water level, exceeding the capacity of the feed pump
- Check that feed pump and inlet water strainers are clear
- Check for leaks in the water lines
- Check for an air-lock in the water inlet lines
- Verify that the feed pump is delivering water
 - Pump mechanical failure
 - Bad electrical connections
- Check that pressure pump inlet and discharge valves are not stuck open (common problem if not flushed after use with sea water)
- Check for water going out of the bypass – pressure regulator failure

5. WATER IN CRANK CASE

- Check the pump seals (feeding water at greater than 50-psi can force water past the seals and damage the seals)
- Check the plungers for cracks
- Check the plunger rod O-ring



6. AFTER RELEASING THE MECHANICAL TRIGGER, WATER IS STILL LEAKING OUT OF THE LANCE

- Replace the mechanical trigger valve assembly in the lance handle

7. LANCE IS NOT CLEANING PROPERLY

- Verify that the system is operating at the correct pressure (2,200-psi)
- Remove the lance from water with the system at operating pressure and trigger in the closed or "OFF" position. If water is leaking out of the barrel or handle, the trigger valve assembly should be replaced
- Check cavitation and zero-thrust nozzles for foreign particles
 - Visual inspection
 - Insert a small wire into nozzle orifices to check for obstruction(s)
 - Remove trigger valve assembly and "backflush" with compressed air or pressurized water

This space intentionally left blank

(EOS)



9.0 REPLACEMENT PARTS

CaviBlaster 2022-U POWER UNIT REPLACEMENT PARTS			
RECOMMENDED ORDER QTY	QTY USED PER ASSEMBLY	PART DESCRIPTION	PART NUMBER
1	1	Feed pump base plate / strainer	54274
1	1	Inlet strainer cartridge	3260.02
1	1	Engine air filter	ED2175-165-S
2	1	Engine oil filter	ED2175-285-S
1	1	Engine fuel filter	ED2175-288-S
1	1	Timing belt	ED2440-338-S
1	1	Alternator belt	ED2440-308-S
2	1	Drive belt	2BX47
1	1	Seal kit	UD-12
1	1	Valve kit	UD-93
1	1	Brass kit	UD-19
1	1	Plunger rod o-ring kit	UD-123
1	1	Pressure regulating unloader repair kit	UB 402 / K
1	1	Relief valve repair kit	UB 402 / K
1	1	Trigger valve assembly repair kit	203300490

All parts can be ordered from:

CAVIDYNE™, LLC

PO Box 358628
Gainesville, FL 32635 USA

Phone: (352) 275-5319

Email: support@cavidyne.com

Web Site: <http://www.caviblasters.com>

(EOS)



CAVIBLASTER™

APPENDIX - COMPONENT LITERATURE

Kohler Diesel Engine Model KDW 1404	Engine Spec Sheet Engine Owner's Manual Engine Work Shop Manual Engine Troubleshooting Guide
NORAM Centrifugal Clutch Model 3700P008	Spec Sheet Clutch Drawing
Udor Pump Model NX 75/150	Pump Spec Sheet Pump Exploded View Pump Dimensions Pump Service Guide Pump Torque Specs
Udor Unloader & Relief Valve Model UB 402	Valve Spec Sheet
Suttner Trigger Gun Model ST-3300	Gun Schematic Drawing
Warranties	Cavidyne Kohler Engines Udor USA Suttner

(EOS)